

SECTION 4

PARTS REMOVAL & REPLACEMENT

www.tandtrepair.com

GENERAL

This section covers the procedure for the removal of covers, major components and modules.

The sequence of the steps of procedure is arranged to save time in removal and replacement work, and to avoid, as much as possible, upsetting critical adjustments.

The removal and replacement of major components or modules unavoidably upsets some adjustments. Before proceeding to the final adjustments:

1. Verify all interlocking adjustments.
2. Proper sequence of adjustments must be observed, as referenced in the replacement procedure.

Failure to use the sequential checklist may:

1. Upset previous adjustments.
2. Create new functional faults.
3. Increase the number of readjustments required to put the machine in proper working order.

IMPORTANT

FAILURE TO FOLLOW THE SEQUENTIAL ORDER OF ADJUSTMENTS CAN RESULT IN SELF-DEFEATING EFFORT AND TIME-CONSUMING READJUSTMENTS.

FACE PLATE

- Removal:
1. Turn back of machine to face front of bench.
 2. Loosen hex socket screw **A** .
 3. Remove screw **B** at bottom of face plate.
 4. Ease face plate off locating pin at top of arm.

- Replacement:
1. Guide face plate on to locating pin.
 2. Align screw hole in place with hole in arm. Thread screw **B** into arm. Seat face plate correctly before tightening screw **B** first and set screw **A** last.

TOP COVER

- Removal:
1. Remove arm top cover locking screw **D** .
 2. Slightly raise right rear corner of top cover. Illustration **C** .
 3. Place thumb into take-up lever well and press top cover to the right.
 4. Lift right end of cover and remove from machine.

- Replacement:
1. Place cover flat on top of the machine arm with the hold-down clamps are properly located under the hold-down screw studs.
 2. Press cover to the left being sure the hold-down clamps are properly located under the hold-down screw studs.
 3. Replace arm top cover locking screw **D** .

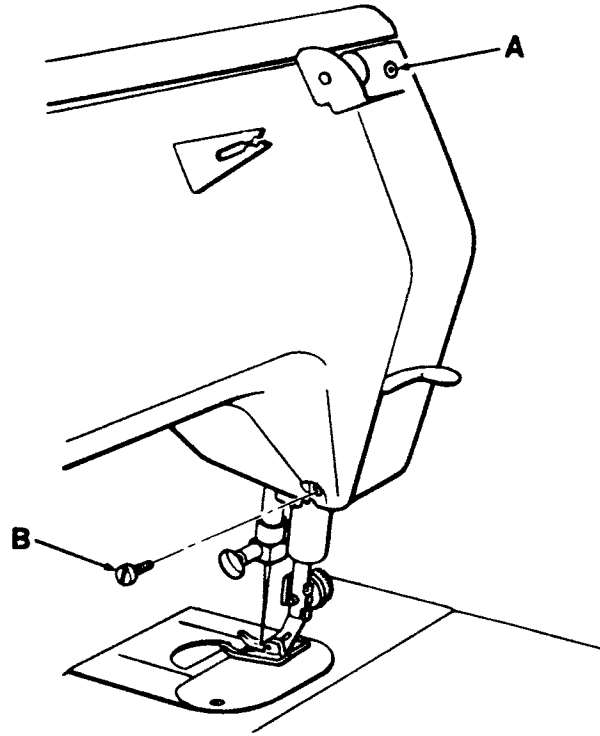

Note: the 2000 does not have this screw. The top will just slide off from left to right. Gently lift it very very little on the back side. Using the left hand, push as shown. It will pop off.

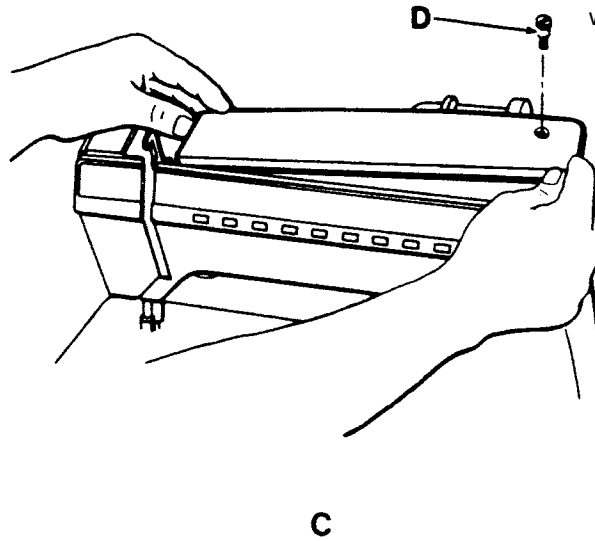

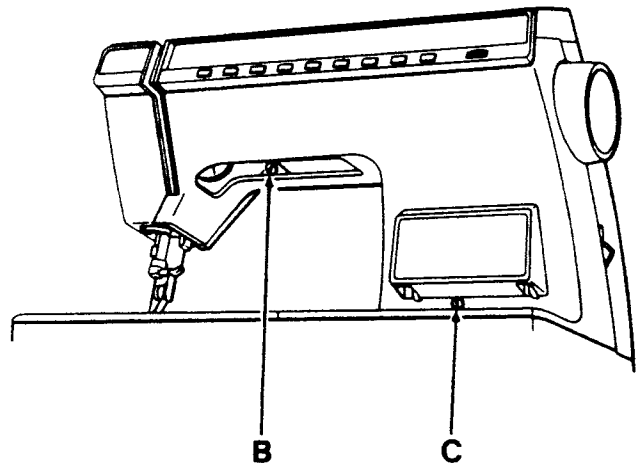
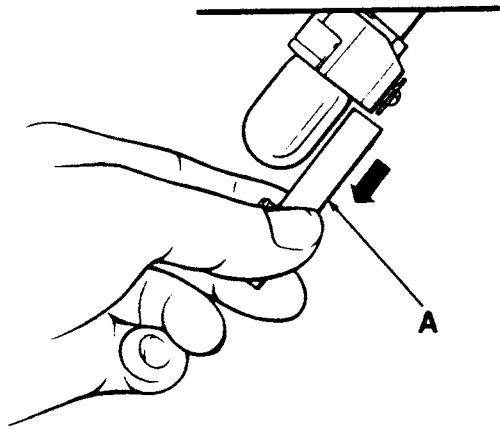

www.tandtrepair.com

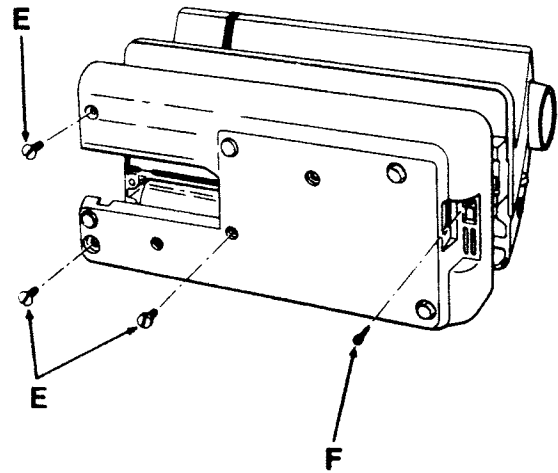
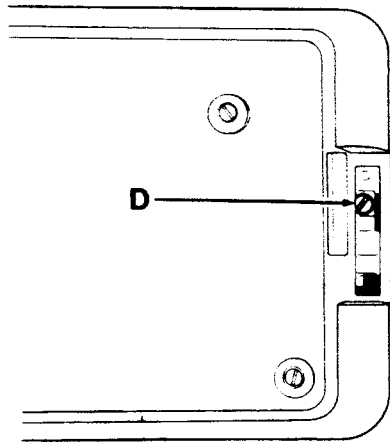

FRONT COVER

Removal:

1. Lower light and remove light lens **A** by pulling it toward bed of machine. Return light socket to its stored position.
2. Remove cover screw **B** with cushion spring to right of tension dial.
3. Remove cover screw **C** with washer under control panel cover.
4. Remove cover screw **D** located inside of recess in casting above the motor plug.
5. Pull front cover toward you about 1/2". If there is resistance, look for interference of cover with lens spring clip. Grasp lower right hand end of panel and draw panel toward you, pivoting on the left end and clearing harness along left side of override board.
6. Tilt right end upward and pivot on front end to clear tension and light reflector.

Replacement:

Replacement is the same as removal in reverse order.

BOTTOM COVER

Removal:

1. Lay machine on its back on a soft cloth and remove three slotted screw **E**, and slotted self tapping screw **F**.
2. Draw bottom cover off the machine.

Replacement:

Replacement is the same as removal in reverse order.